

## OFFERING AWP OPERATORS AND RETAILERS MEI PERFORMANCE

**mei** | geo gravity™

MEI GEO® Gravity™ is a multi-width bill validator that provides a higher level of performance for applications that do not require a cashbox. The product is built upon MEI technology, which is relied upon for over two billion transactions per week in over 100 countries.

Proven algorithms have been implemented into MEI GEO® Gravity™ based on the ability of MEI CASHFLOW® SC to improve profitability in casinos, kiosks, self-checkout equipment and smart safes worldwide. That expertise can now be applied in additional market segments — expanding expectations for acceptance rates, security and jam performance where MEI hasn't previously participated.

MEI Gravity™ is the initial product from the MEI GEO® portfolio. The stackerless offering, like the entire product family, is designed to provide a newfound value for applications that historically had to settle for low cost alternatives. The introduction of MEI GEO® product line allows AWP operators and retailers to select the right balance of performance and price for every application.

The reliability inherent in MEI's signature yellow coloring will be evident to an entire group of new customers. And, as always, the MEI value proposition will be apparent with reduced maintenance costs and increased profitability.

**Please contact your MEI sales associate to specify MEI GEO® Gravity™ when the solution doesn't require a cashbox.**



**mei**  
www.meigroup.com

**Proven performance. Increased profits.**

## TECHNICAL SPECIFICATIONS

Bill width:	up to 85mm
Operating voltage:	12VDC [- + 10%], 500ma: 6 Watts
Operating temperature:	5 to 55 C
Maximum humidity:	90%
Protocols:	ccTalk®, Serial, Pulse, Parallel (Binary and BCD), NISR
Dimensions:	w x d x h: 96mm x 91mm x 80mm
Bezel/mounting options:	standard and glass door
Acceptance rate:	95% first pass acceptance
Warranty:	1 year

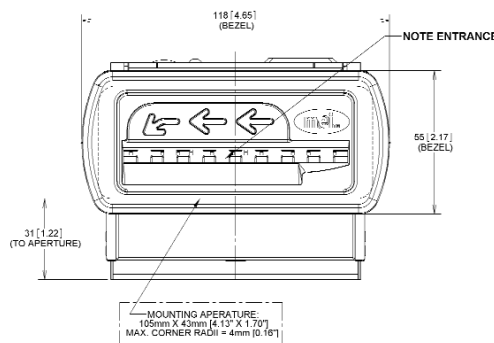
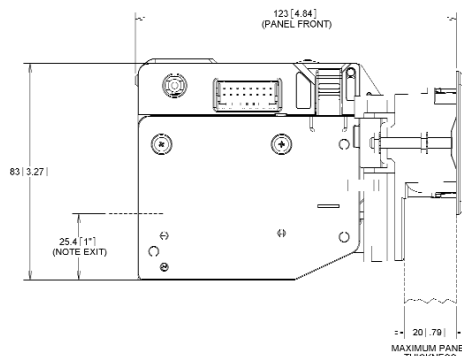

### MEI GEO® SL Part Number Breakdown

**SLSA1**

<b>a</b> Series	SL (GEO® Stackless)
<b>b</b> Model	S=Standard R=RS232 C=ccTalk® A=ccTalk® (AWP)
<b>c</b> Bezel/ Faceplate Type	A=Standard Bezel/FP, up B=Glass mounting Bezel/FP D=Glass mounting Bezel/FP (Metal)
<b>d</b> Options	0=None 1=Cotton Catcher 2=MAS

### MECHANICAL ANTI-STRINGING (MAS) DEVICE

The history of mechanical manipulations in the AWP market space led MEI to develop an additional layer of protection against fraud. A mechanical anti-stringing device (MAS) can be attached to MEI GEO® Gravity™ for use in markets susceptible to criminal activity.



### MEI LOCATIONS:

#### UNITED STATES

**Corporate Headquarters**  
1301 Wilson Drive  
West Chester, PA 19380  
Telephone: 1 610 430 2700  
Facsimile: 1 610 430 2694  
Customer Service: 1 800 345 8215  
Technical Support: 1 800 345 8172

#### Las Vegas, NV

Telephone: 1 702 873 4866  
Facsimile: 1 702 873 6401

#### UNITED KINGDOM

Telephone: +44 (0) 118 938 1100  
Facsimile: +44 (0) 118 938 1120

#### SWITZERLAND

Telephone: +41 (0) 22 884 0505  
Facsimile: +41 (0) 22 884 0504

#### AUSTRALIA

Telephone: +61 2 8875 7753  
Facsimile: +61 2 8875 7957

#### CANADA

Telephone: +1 905 492 0851  
Facsimile: +1 905 492 0853

#### JAPAN

Telephone: +81 3 3221 8466  
Facsimile: +81 3 3221 8465

#### SPAIN

Telephone: +34 91 749 7516  
Facsimile: +34 91 749 9356

#### FRANCE

Telephone: +33 (0) 1 57 32 30 23  
Facsimile: +33 (0) 1 55 69 56 10

#### GERMANY

Telephone: +49 695 007 0420  
Facsimile: +49 695 007 0421

#### ITALY

Telephone: +39 02 69633722  
Facsimile: +39 02 69633723